

fnc2000/AB Controllers

The **fnc2000/AB** is a control device which can plug directly into any of the **flex7** range of connection units or a 7-pole single socket outlet. Working with at least a switch or together with a plug-in sensor head, the device will control the connected mains rated luminaires ON and OFF. The exact operation will largely depend on which of the input devices are connected. Note that any connected switch or sensor head will be operating at ELV.

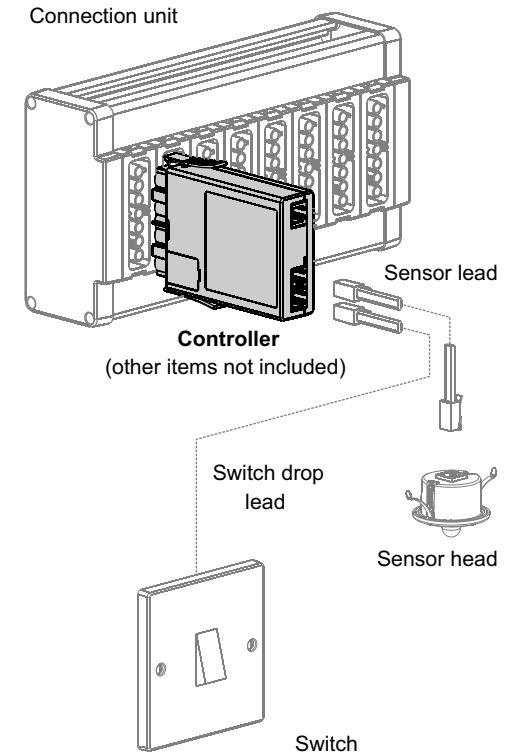

Configuring the fnc2000/AB controller & wiring the connection unit

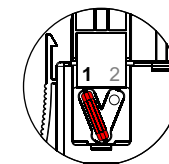

Link in position 1
Lights can remain ON during an emergency test. Wire connection unit as shown in option A. See back page for details.

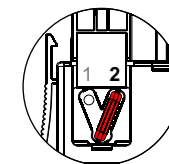

Link in position 2
Lights will switch OFF during an emergency test. Wire connection unit as shown in option A or B. See back page for details.

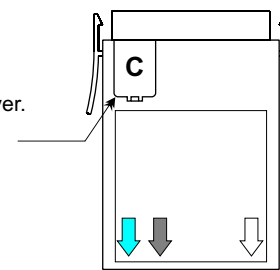

Prise open lid 'C' using a screw driver. Position link as required.

Rating

Supply Voltage : 220V-240V, 50Hz, ~

Load

Fluorescent & Incandescent Lighting : 6A
Compact Fluorescent Lighting : 3A

Circuit diagram for fnc2000/AB Controller

fnc2000/AB

See front page for details on configuring link

Emergency luminaire

Luminaire

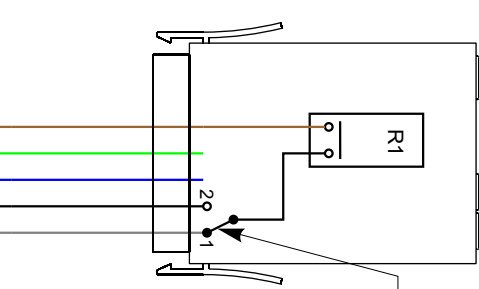

* L SW (Brown)
Earth (Grn/Yel)
Neutral (Blue)
L EM (Black)

* L SW (Brown)
Earth (Grn/Yel)
Neutral (Blue)

* Core colours if using 3 & 4-core flex7 prewired plug and leads

Connection unit

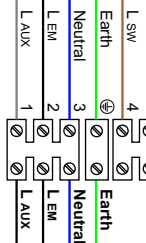
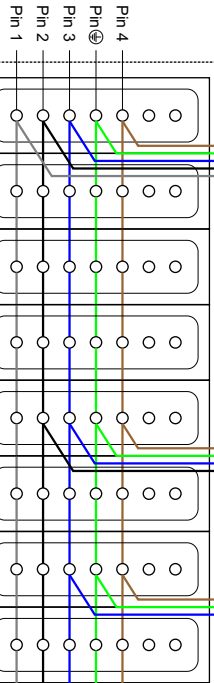

Wiring option A

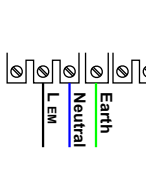

Wiring option B

Using a fnc2000/AB controller with a switch only

* Refer to leaflet *Networking Sensors*,
leaflet number 17/245.

Note:

Multiple switches can be connected in parallel. 'Y' connectors are available to enable two switch drop leads to be connected into one point. (Part No. *fsy/A* - adaptor)

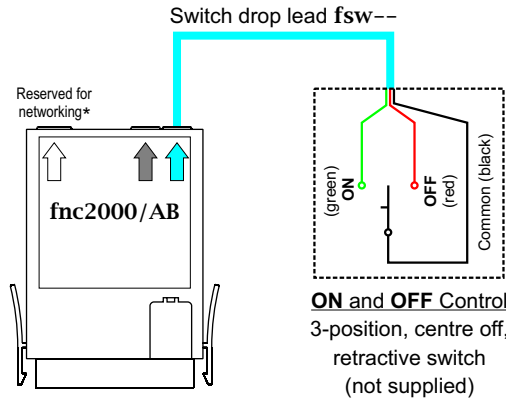

Operation:

Switch control:

An ON pulse - turns the lights ON.
An OFF pulse - turns the lights OFF.

Using fnc2000/AB controller with a sensor head and a switch

* Refer to leaflet *Networking Sensors*,
leaflet number 17/245.

Note:

For best operation it is advisable that occupancy coverage extends to cover the wall switch.

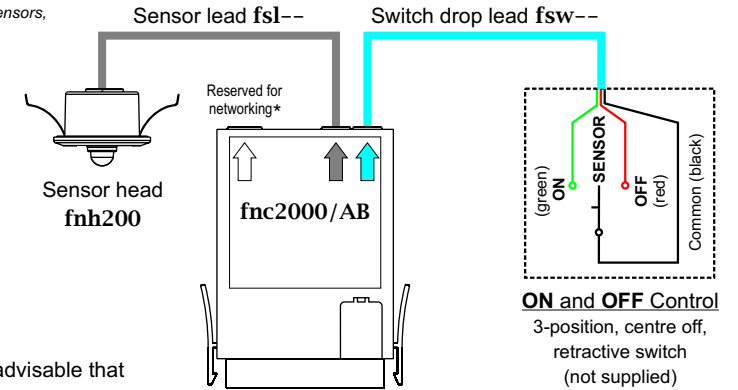

Note:

Multiple switches can be connected in parallel. 'Y' connectors are available to enable two switch drop leads to be connected into one point. (Part No. *fsy/A* - adaptor).

Operation:

Switch control: An ON pulse - turns the lights ON.
An OFF pulse - turns the lights OFF.

Absence detection: When occupancy is no longer detected, lights will switch OFF after a pre-selected *time-out* period.

Note: Alternative operational options not necessarily shown above are available using the *frc/set* setup remote control.
Full instructions for setting up the sensor are supplied with the sensor head and the *frc/set* remote control - both ordered separately.