

Circuit diagram for **fnc4000D(X, A)/E** Controllers

fnc4000D(X, A)/E - Controllers

Includes Integral Emergency Test

The **fnc4000D(X, A)/E** are all control devices which can plug directly into any of the **flex7** 7-pole range of connection units or a 7-pole single socket outlet. Working with a switch or together with a plug-in sensor head, the device will control the connected mains rated luminaires ON/OFF, DIM up or down and will be able to carry out an emergency test. Note that any connected switch or sensor head will be operating at ELV.

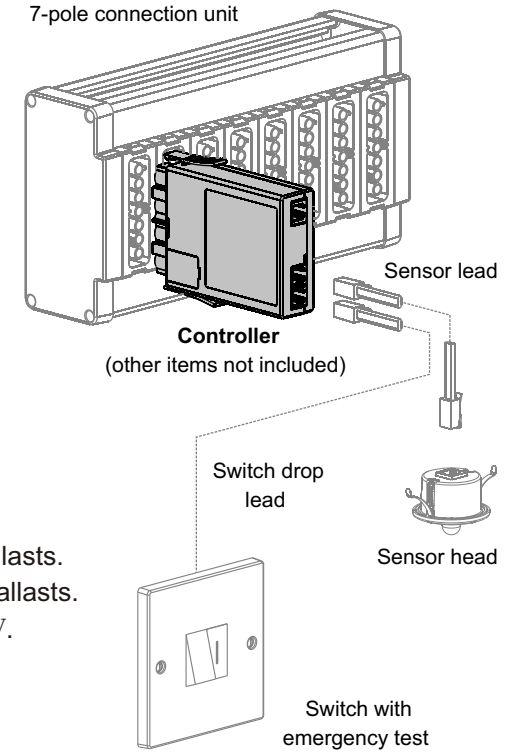

Three products are available:
fnc4000D/E : DSI digital dimmable ballasts.
fnc4000X/E : DALI digital dimmable ballasts.
fnc4000A/E : Analogue ballasts 0-10V.

Please ensure the correct product is selected for the type of ballast being used as incorrect connection may damage the controller.

Configuring the **fnc4000D(X, A)/E** controller & wiring the connection unit

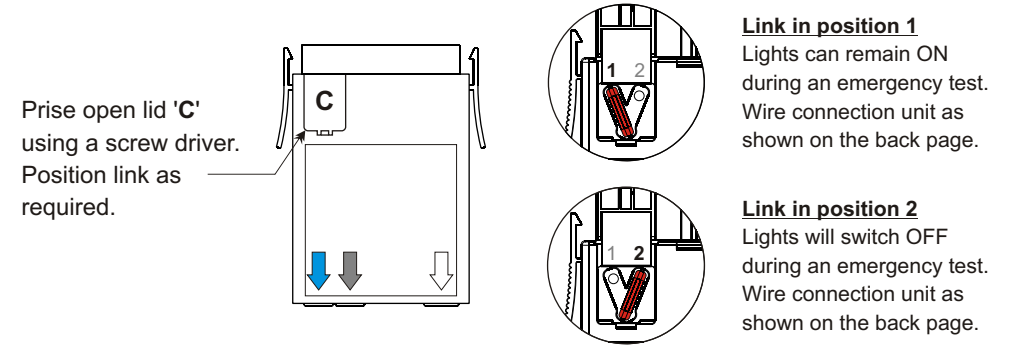

Product	Control Type	Max. no. of Ballast	Rating
fnc4000D/E	DSI Digital	25	Supply Voltage : 220V-240V, 50Hz, ~
fnc4000X/E	DALI Digital	25	Load Fluorescent & Incandescent Lighting : 6A
fnc4000A/E	Analogue 0-10V	25	Compact Fluorescent Lighting : 3A

Using a fnc4000D(X, A)/E controller with a sensor head & override switch

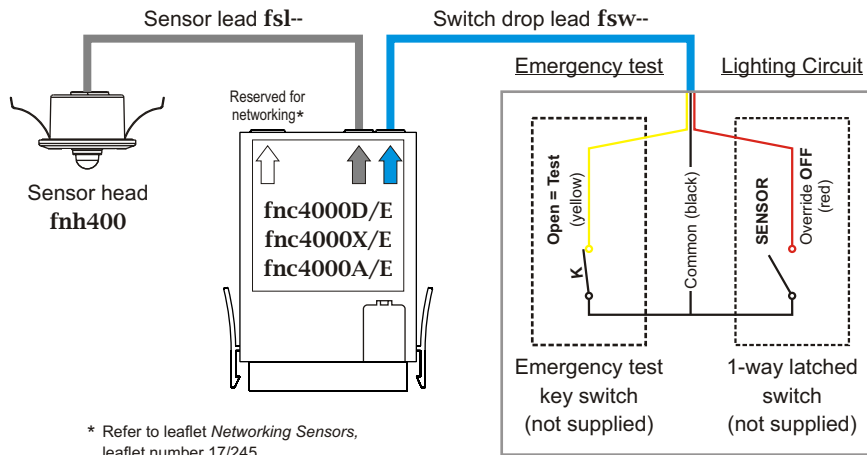

* Refer to leaflet *Networking Sensors*, leaflet number 17/245.

Override OFF only
with emergency test

See table below for other switching options

Note:

For safe operation it is advisable that occupancy coverage extends to cover the wall switch. In this way, operating the switch to 'SENSOR' position ensures the lights turn ON.

Note:

If your room requires 2-way switching, a special 'Y' connector is available to enable two switch drop leads to be connected. (Part No. fsy/2e/2 - OFF control from 2 x 2-way switches)

Other switching options incorporating override ON

Note:

You may not be able to claim enhanced capital allowances under the Carbon Trust scheme if you incorporate local 'override ON' switches in your occupancy sensor scheme.

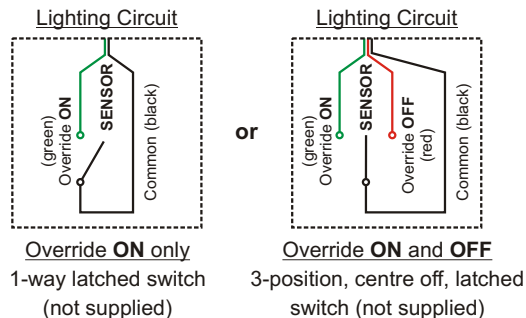

Emergency test

Wire the yellow and black wire as shown in the above diagrams.

Operation for the light circuit:

Occupancy detection: Provided the wall switch is in the 'Sensor' position the lights will switch ON whenever there is occupancy detected by the sensor head. When occupancy is no longer detected, lights will switch OFF after a pre-selected *time-out* period.

Daylight linking: When lights are ON due to occupancy their light output will adjust to compensate for any changes in ambient light in order to maintain a constant light level under the sensor head - the *target level*.

Override switch operation: Override OFF or override ON takes priority over sensing. (Override ON means full bright).

Operation for the emergency test:

Operate key switch to carry out an emergency test.

Note: Alternative operational options not necessarily shown above are available using the frc/set setup remote control.

Full instructions for setting up the sensor are supplied with the sensor head and the frc/set remote control - both ordered separately.