

# fnc2000/AT/2 - Controllers

Includes Additional Switch Circuit

The **fnc2000/AT/2** is a control device which plugs directly into a special type of **flex7** connection unit; the **fi--/fnc2** or **fcB--/fnc2**. Working with switches or together with a plug-in sensor head, the device can control two switching circuits ON and OFF. The exact operation will depend on which, if any, sensor head is fitted. Note that any connected switch or

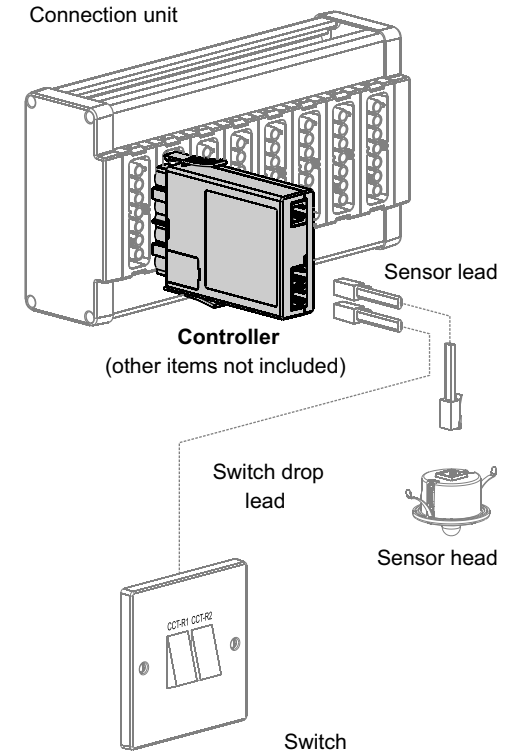

## Configuring the fnc2000/AT/2 controller and wiring the connection unit

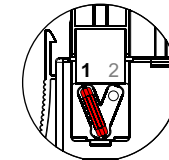

**Link MUST be in position 1 as shown**

Wire connection unit as shown on the back page.

### Rating

Supply Voltage : 220V-240V, 50Hz, ~

#### Load on Lighting Circuit - R1

Fluorescent & Incandescent Lighting : 6A

Compact Fluorescent Lighting : 3A

#### Load on Lighting Circuit - R2

Fluorescent & Incandescent Lighting : 6A

Compact Fluorescent Lighting : 3A

**Total Maximum Load : 10A**

To view, prise open lid 'C' using a screw driver.

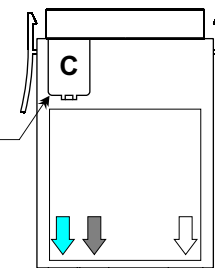

## Circuit diagram for fnc2000/AT/2 Controllers

fnc2000/AT/2  
See front page for details on the link.

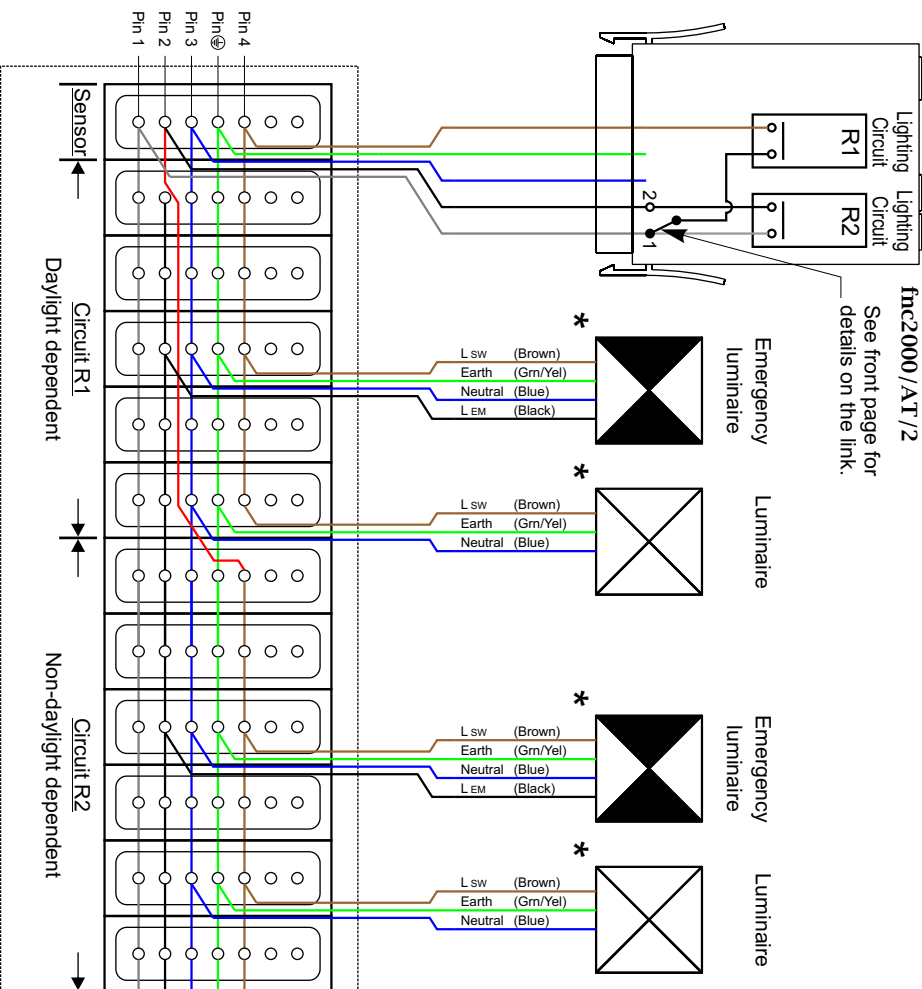

Connection unit shown: **fcB12/fnc2**

**IMPORTANT**  
A special connection unit is required,  
Part number: **fi--/fnc2** or **fcB--/fnc2**

\* Core colours if using 3 & 4-core flex7 prewired plug and leads

**Wiring Option A**  
Lights can remain ON during an emergency test.

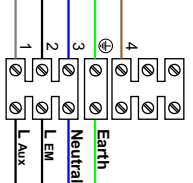

**Wiring Option B**  
Lights will switch OFF during an emergency test.

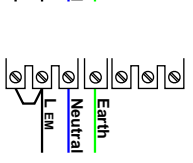

## Using a fnc2000/AT/2 controller with a switch only

\* Refer to leaflet *Networking Sensors*, leaflet number 17/245.

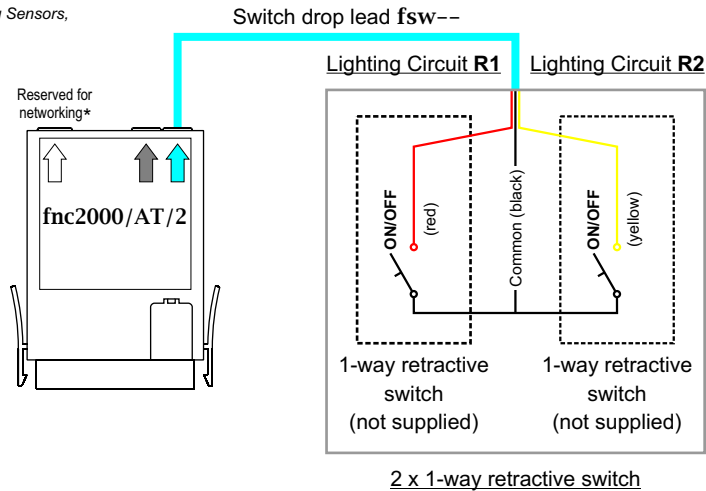

### Operation

#### Circuit R1

**Switch Control:** - A pulse - toggles the lights ON or OFF.

#### Circuit R2

**Switch Control:** - A pulse - toggles the lights ON or OFF.

## Using an fnc2000/AT/2 controller with a sensor head and override switch

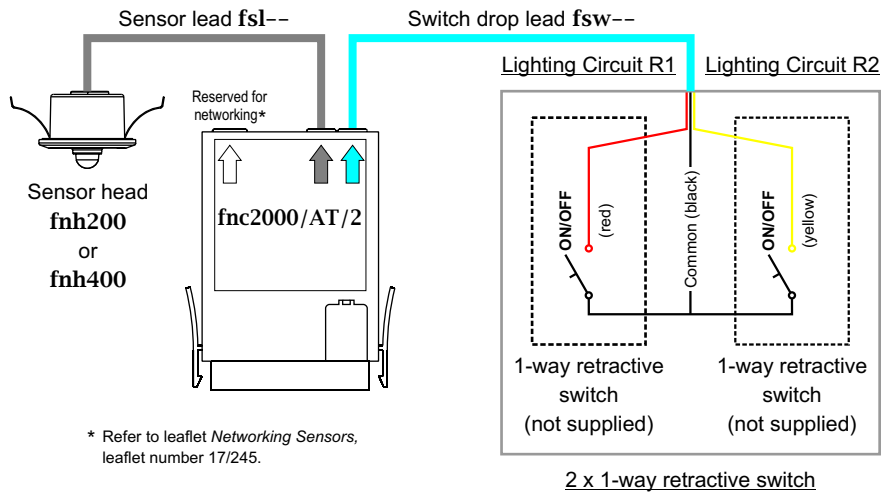

\* Refer to leaflet *Networking Sensors*, leaflet number 17/245.

### Note:

For safe operation it is advisable that occupancy coverage extends to cover the wall switches. In this way, operating the switches to their 'SENSOR' positions will ensure the lights turn ON.

## Operation

### If the sensor head is of type fnh200

#### Circuit R1

**Switch Control:** - A pulse - toggles the lights ON or OFF.

**Absence detection:** - When occupancy is no longer detected, lights will switch OFF after a pre-selected time-out.

#### Circuit R2

As for **Circuit R1**.

### If the sensor head is of type fnh400

#### Circuit R1

**Switch Control:** - A pulse - toggles the lights ON and OFF.

**Absence detection:** - When occupancy is no longer detected, lights will switch OFF after a pre-selected time-out.

**Daylight dependency:** - During periods of occupancy (or whilst occupancy is timing out) the lights may switch OFF if the ambient light detected under the sensor head sufficiently exceeds the *set-level*. Conversely the lights may switch back on again should the ambient light fall below the *set-level*.

Note: By default daylight dependency on this sensor is disabled. If required please refer to your **frc/set** remote control instructions for enabling / disabling *daylight dependency*.

#### Circuit R2

As for **Circuit R1** with the exception that **Circuit R2** will never be daylight dependent.

**Note:** Alternative operational options not necessarily shown above are available using the **frc/set** setup remote control. Full instructions for setting up the sensor are supplied with the sensor head and the **frc/set** remote control.