

The **fns3200D(X, A)** sensor kit plugs directly into any of the **flex7** 7-pole range of connection units or a 7-pole single socket outlet to provide control of the connected mains rated luminaires. Control is ON/OFF/DIM, dependent on occupancy.

Note: Dimming can only occur using frc/ handset.

The kit comprises a controller, sensor head, and sensor lead.

Three products are available:

fns3200D for DSI digital dimmable ballasts.

fns3200X for DALI digital dimmable ballasts.

Fns3200A for Analogue ballasts 0-10V.

Please ensure the correct product is selected for the type of ballast being used as incorrect connection may damage the controller.

This product should only be installed by a qualified electrician.

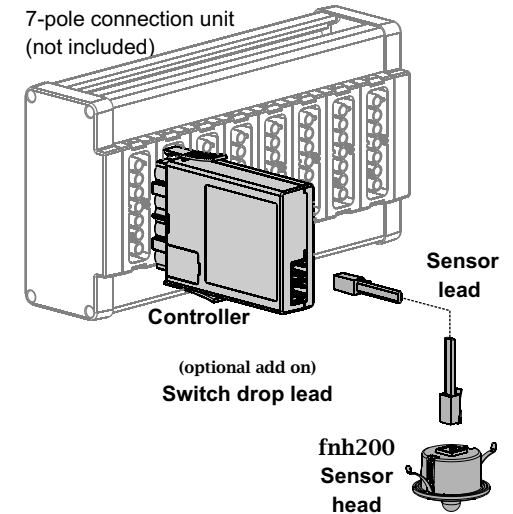

Sensor head and occupancy detection performance

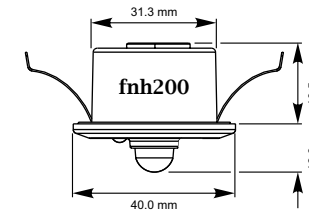
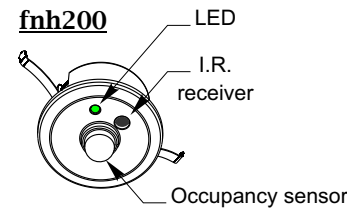

The sensor head fits into a 32mm diameter hole, with clips which can grip ceiling panels down to 1.5mm thick.

The sensor head has a rectangular occupancy detection range broadly 7.4m x 5.6m at a ceiling height of 2.5m (Longest length of detection aligning with the spring clips). As the ceiling height increases so will the overall detection area but sensitivity to small movements will decrease.

Note: Make sure that the sensor is not adjacent to circulating air, heaters or lamps.

Detection Zone

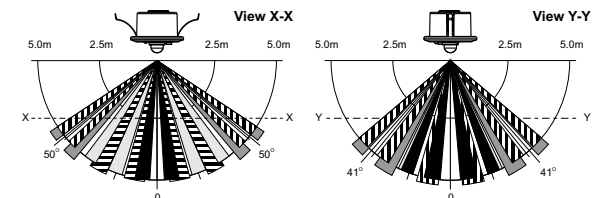
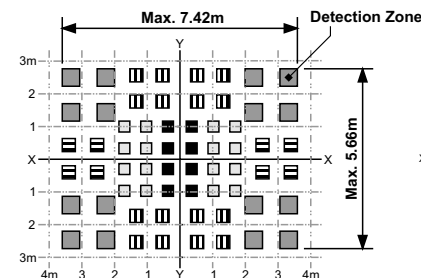

The X-Y cross-sectional diagram shows the detection area. The differences in the detection zone patterns indicate the projections of the 16 lenses with a single focal point. Movement of an object with higher than background temperature, between the detection zones, will be detected.

Configuring the controller and wiring the connection unit

Prise open lid 'C' using a screw driver. Position link as required.

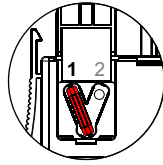
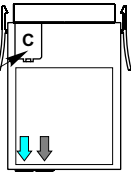

Link in position 1

Lights can remain ON during an emergency test. Wire connection unit as shown in option A. See 'Wiring' opposite page for details.

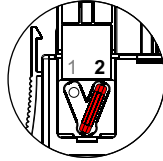

Link in position 2

Lights will switch OFF during an emergency test. Wire connection unit as shown in option A or B. See 'Wiring' opposite page for details.

Rating

Supply Voltage : 220V-240V, 50Hz, ~

Load

Flourescent & Incandescent Lighting : 6A
Compact Flourescent Lighting : 3A

Maximum number of Ballast

fns3400D (DSI Digital control) : 25
fns3400X (DALI Digital control) : 25

Wiring

* Core colours if using 5 & 6-core flex7 pre-wired plug and leads

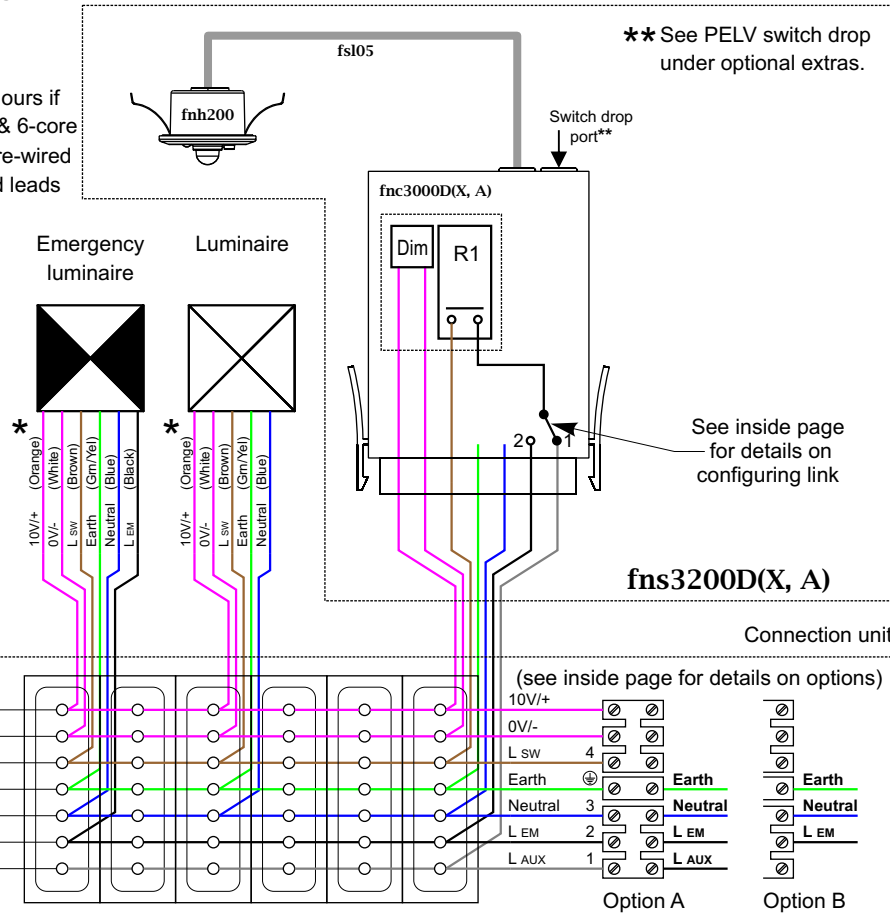

Operation:

Occupancy detection: Lights will switch ON whenever there is occupancy detected by the sensor head. When occupancy is no longer detected, lights will switch OFF after a pre-selected *time-out* period (default 20 minutes).

Dimming:

Can only be adjusted using the frc/ remote hand set.

Setting Up

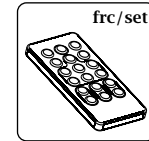

Setup Remote Control – frc/set

The sensor can only be setup by using an **frc/set** remote control - ordered separately. Full instructions for setting up the sensor are supplied with the **frc/set** remote control.

Optional Extras

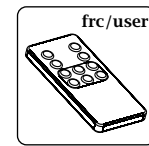

User Remote Control – frc/user

The **frc/user** remote control is a convenient method for the user to control the lighting remotely. Lights can be temporarily overridden ON or OFF and in cases where the lighting control is dimmable, dimmed UP or DOWN. In addition, up to six preset light levels can be stored and recalled.

Note: Unlike the **frc/set** remote control the **frc/user** remote control can not be used to setup or change occupancy time-out settings.

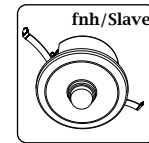

Increasing Occupancy Coverage – fnh/slave

Occupancy coverage can be increased by adding up to a maximum of five slave sensor heads (**fnh/slave**) to your existing sensor head. The **fnh/slave** comes complete with a 'Y' adaptor to facilitate connection.

A connecting lead may also be required, part number **fsLXX** (XX = length /5m).

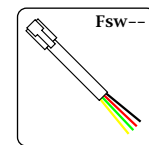

PELV – Switch Drop

Adding a PELV switch drop allows you to override your occupancy sensor off

For fsw--
-- = length in meters in multiples of 5m i.e. Fsw05, Fsw10, fsw15.

Latched

Use a 1way latched switch for override off control. (Switch not supplied)

