

Operation:

The controller plugs directly into any of the **flex7** range of connection units and will control the connected mains rated luminaires as follows:

Occupancy detection: Lights will switch ON whenever there is occupancy detected by the sensor head. When occupancy is no longer detected, lights will switch OFF after a pre-selected *time-out* period.

Daylight dependency: During periods of occupancy the lights will switch OFF if the ambient light detected under the sensor head exceeds the *set level*.

Setting Up

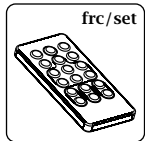

Setup Remote Control – frc/set

The sensor can only be setup by using an **frc/set** remote control - ordered separately. Full instructions for setting up the sensor are supplied with the **frc/set** remote control.

Optional Extras

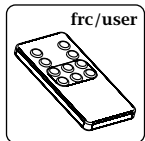

User Remote Control – frc/user

The **frc/user** remote control is a convenient method for the user to control the lighting remotely. Lights can be temporarily overridden ON or OFF and in cases where the lighting control is dimmable, dimmed UP or DOWN. In addition, up to six preset light levels can be stored and recalled.

Note: Unlike the **frc/set** remote control the **frc/user** remote control can not be used to setup or change occupancy time-out settings.

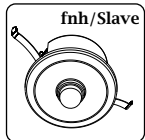

Increasing Occupancy Coverage – fnh/slave

Occupancy coverage can be increased by adding up to a maximum of five slave sensor heads (**fnh/slave**) to your existing sensor head. The **fnh/slave** comes complete with a 'Y' adaptor to facilitate connection.

A connecting lead may also be required, part number **fslXX** (XX = length /5m).

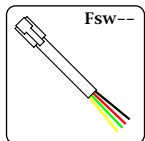

For fsw--
-- = length in
meters in multiples
of 5m i.e. Fsw05,
Fsw10, fsw15 etc.

PELV – Switch Drop

Adding a PELV switch drop allows you to override your occupancy sensor off (fig 1) OR convert your occupancy sensor to absence control (fig 2)

Latched

Use a 1way latched switch for override off control.
(Switch not supplied)

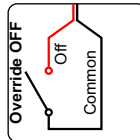

Momentary

Use a 1way retractive switch for absence sensing.
(Switch not supplied)



fns1400 Sensor Kit

C

The **fns1400** sensor kit plugs directly into any of the **flex7** range of connection units or a 7-pole single socket outlet to provide control of the connected mains rated luminaires. Control is ON/OFF dependent on occupancy and daylight detection.

The kit comprises a controller, sensor head and a sensor link lead.

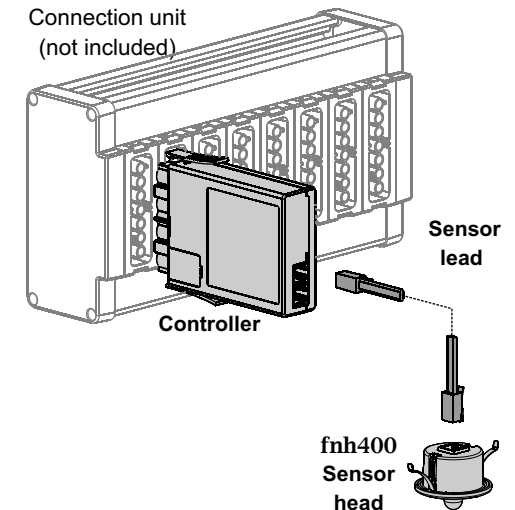

This product should only be installed by a qualified electrician.

Considerations before installation

The **fnh400** sensor head detects both occupancy and light level. However, conditions for optimum light sensing should always have priority over those for occupancy coverage. To achieve effective daylight dependent control, select only an area where the daylight contribution, though changeable, is significant and remains consistent across the area.

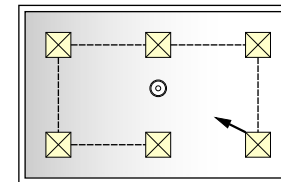

As lamp output across the circuit must be common, it is not possible to provide the 'optimal' ON/OFF state for all areas when some receive more daylight than others.

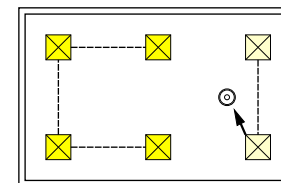
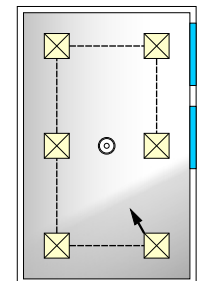

Try to split into zones where the changes in daylight are reasonably consistent. Darker areas may then be controlled via alternative means such as on/off without consideration to daylight. You may even consider sufficient natural light reaches these areas to justify a second daylight sensing circuit.

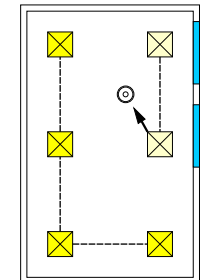

Note: Always fit the sensor head as close as possible to the centre of the group of lights under its control. Do not site where the head could receive direct sunlight

Sensor head and occupancy detection performance

fnh400

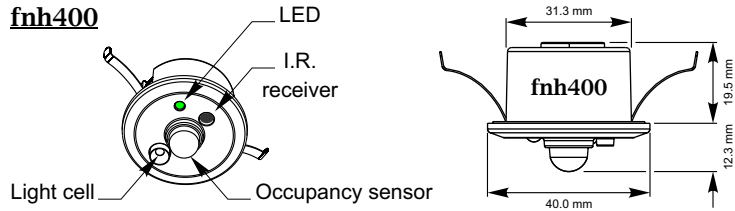

The sensor head fits into a 32mm diameter hole, with clips which can grip ceiling panels down to 1.5mm thick.

The sensor head has a rectangular occupancy detection range broadly 7.4m x 5.6m at a ceiling height of 2.5m (Longest length of detection aligning with the spring clips). As the ceiling height increases so will the overall detection area but sensitivity to small movements will decrease.

Note: Make sure that the sensor is not adjacent to circulating air, heaters or lamps.

Detection Zone

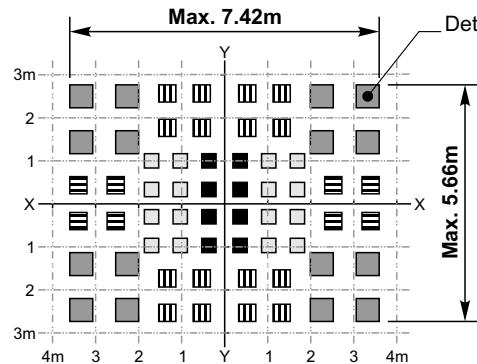
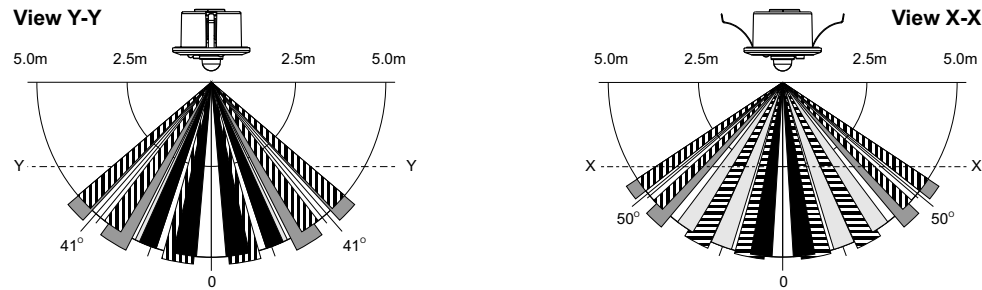

The X-Y cross-sectional diagram shows the detection area.

The differences in the detection zone patterns indicate the projections of the 16 lenses with a single focal point. Movement of an object with higher than background temperature, between the detection zones, will be detected.

Configuring the controller and wiring the connection unit

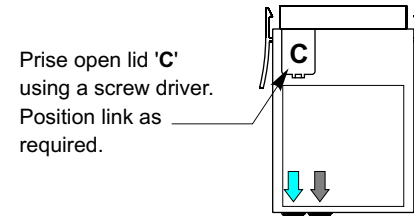

Prise open lid 'C' using a screw driver. Position link as required.

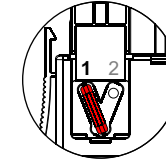

Link in position 1
Lights can remain ON during an emergency test. Wire connection unit as shown in option A. Please see below for details.

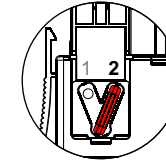

Link in position 2
Lights will switch OFF during an emergency test. Wire connection unit as shown in option A or B. Please see below for details.

Rating

Supply Voltage : 220V-240V, 50Hz, ~

Load

Fluorescent & Incandescent Lighting : 6A

Compact Fluorescent Lighting : 3A

Wiring

** See PELV switch drop under optional extras.

* Core colours if using 3 & 4-core flex7 prewired plug and leads

Emergency luminaire



Luminaire

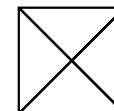

* L sw (Brown)
Earth (Grn/Yel)
Neutral (Blue)
L EM (Black)

* L sw (Brown)
Earth (Grn/Yel)
Neutral (Blue)

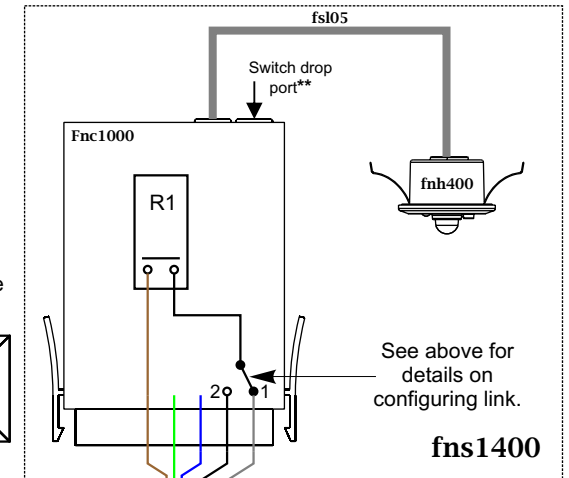

See above for details on configuring link.

fns1400

