

Setting Up

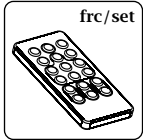

Setup Remote Control – frc/set

The sensor comes factory set with default operational parameters including a standard 20 minutes occupancy time-out. If another time-out period (2, 5, 10, 20 and 40 minutes) or alternative operational parameters are desired, then an frc/set remote control will be required - ordered separately.

Full instructions for setting up the sensor are supplied with the frc/set remote control.

Optional Extras

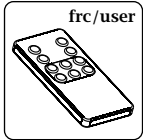

User Remote Control – frc/user

The frc/user remote control is a convenient method for the user to control the lighting remotely. Lights can be temporarily overridden ON or OFF and in cases where the lighting control is dimmable, dimmed UP or DOWN. In addition, up to six preset light levels can be stored and recalled.

Note: Unlike the frc/set remote control the frc/user remote control can not be used to setup or change occupancy time-out settings.



Increasing Occupancy Coverage – fnh/slave

Occupancy coverage can be increased by adding up to a maximum of five slave sensor heads (fnh/slave) to your existing sensor head. The fnh/slave comes complete with a 'Y' adaptor to facilitate connection.

A connecting lead may also be required, part number fslXX (XX = length /5m).

fns1200/U Universal Sensor Kit

F

The fns1200/U universal sensor kit plugs directly into any of the flex7 range of connection units or a 7-pole single socket outlet to provide control of the connected mains rated luminaires. Control is ON/OFF and is dependent on a combination of occupancy detection with an initiating / overriding wall switch (operating at ELV).

Note: The fns1200/U universal sensor can be setup as occupancy or absence sensing.

The kit comprises a controller, a sensor head, a sensor link lead and a switch drop lead.

This product should only be installed by a qualified electrician.

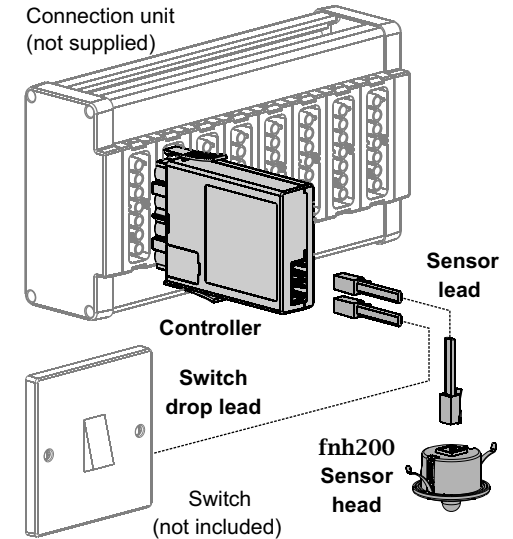

Sensor head and occupancy detection performance

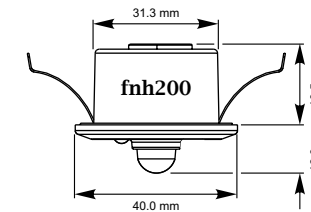
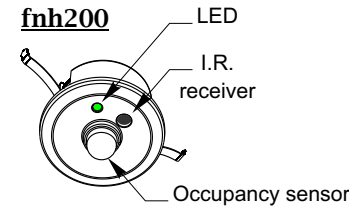

The sensor head fits into a 32mm diameter hole, with clips which can grip ceiling panels down to 1.5mm thick.

The sensor head has a rectangular occupancy detection range broadly 7.4m x 5.6m at a ceiling height of 2.5m (Longest length of detection aligning with the spring clips). As the ceiling height increases so will the overall detection area but sensitivity to small movements will decrease.

Note: Make sure that the sensor is not adjacent to circulating air, heaters or lamps.

Detection Zone

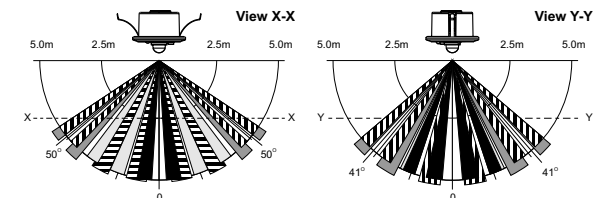
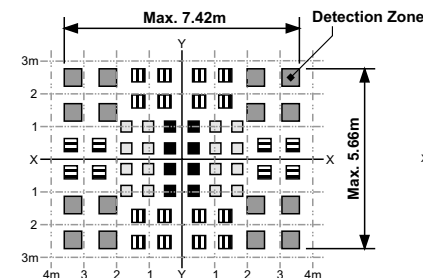

The X-Y cross-sectional diagram shows the detection area. The differences in the detection zone patterns indicate the projections of the 16 lenses with a single focal point. Movement of an object with higher than background temperature, between the detection zones, will be detected.

Configuring the controller and wiring the connection unit

Prise open lid 'C' using a screw driver. Position link as required.

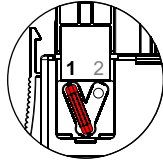
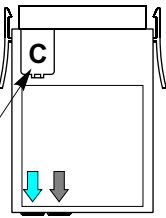

Link in position 1

Lights can remain ON during an emergency test. Wire connection unit as shown in option A. Please see below for details.

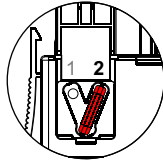

Link in position 2

Lights will switch OFF during an emergency test. Wire connection unit as shown in option A or B. Please see below for details.

Rating

Supply Voltage : 220V-240V, 50Hz, ~

Load

Fluorescent & Incandescent Lighting : 6A

Compact Fluorescent Lighting : 3A

Wiring

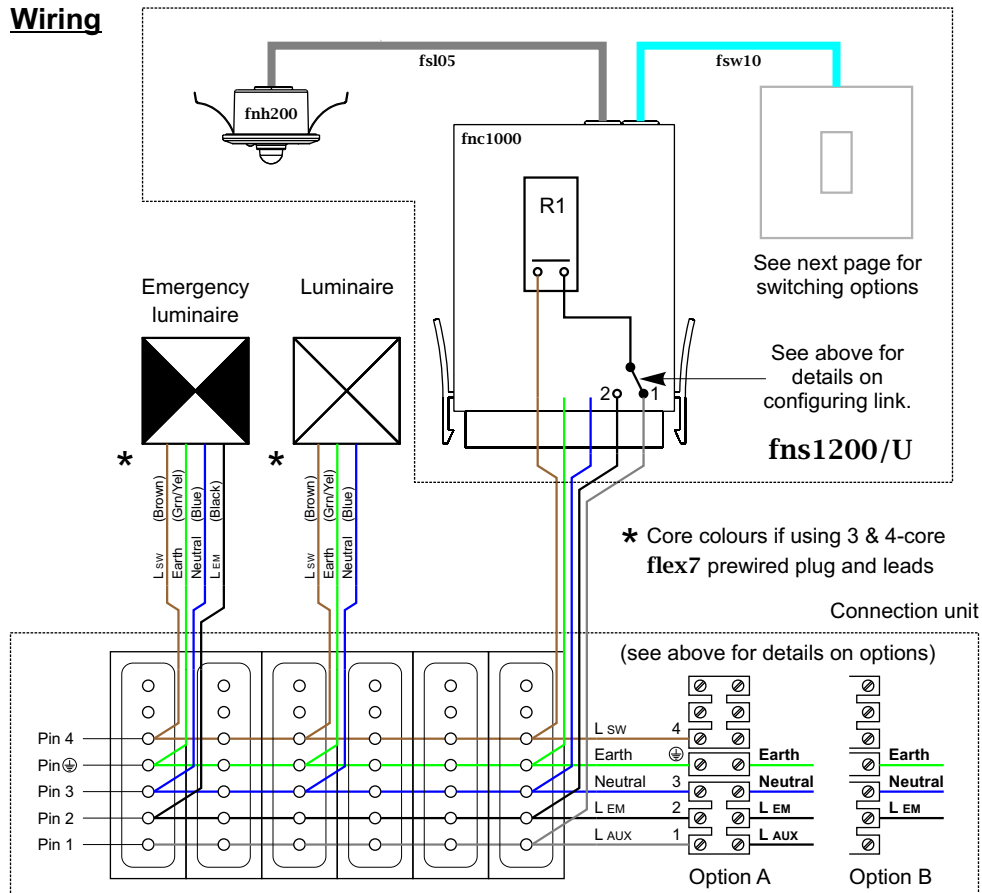

Switching Options

Absence Sensing in conjunction with a 1-way Retractive Switch

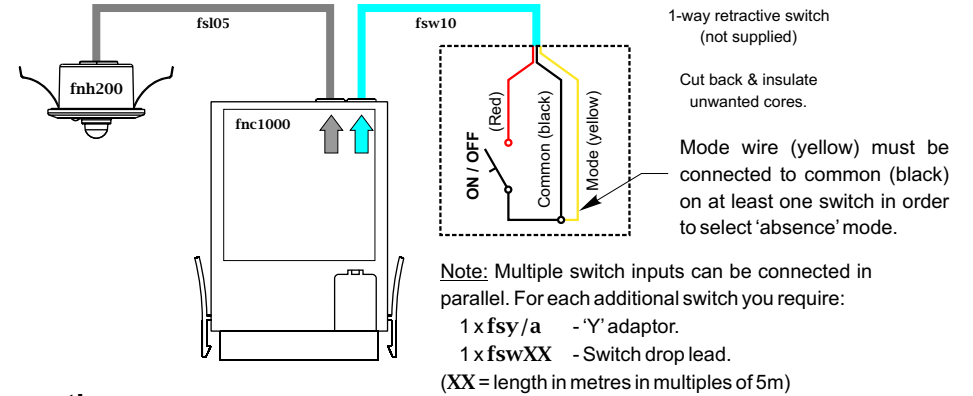

Operation

Switch control: A pulse - toggles the lights ON and OFF.

Absence detection: When occupancy is no longer detected, lights will switch OFF after a pre-selected *time-out* period. Note: By default, absence sensors do not switch lights on due to occupancy, however with an frc/set setup remote control it is possible to reconfigure the unit to initiate the lights ON with first occupancy - This is not true occupancy detection as it can only occur where occupancy has timed out e.g. first thing in the morning.

Occupancy Sensing in conjunction with a 1-way Latched Switch

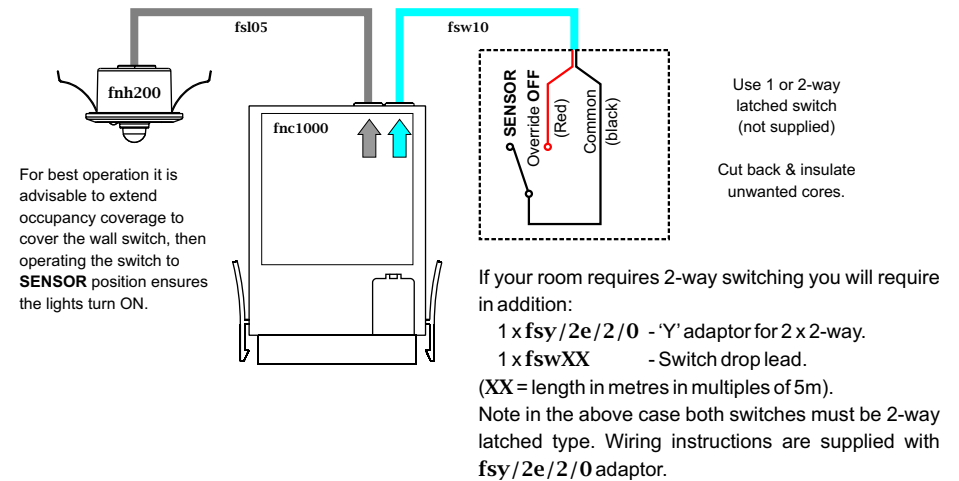

Operation

Occupancy detection: Provided the wall switch is in the 'Sensor' position the lights will switch ON whenever there is occupancy detected by the sensor head. When occupancy is no longer detected, lights will switch OFF after a pre-selected *time-out* period.

Override switch operation: Override OFF takes priority over occupancy sensing.