

fnc2000/2 - Controllers

Includes Additional Switch Circuit

The **fnc2000/2** is a control device which plugs directly into a special type of **eZeBox** connection units; the **f2u--**. Working with switches or together with a sensor head, the device can control two switching circuits ON/OFF. The exact operation will depend on which, if any, type of sensor head is fitted. Note that any connected switch or sensor head will be operating at ELV.

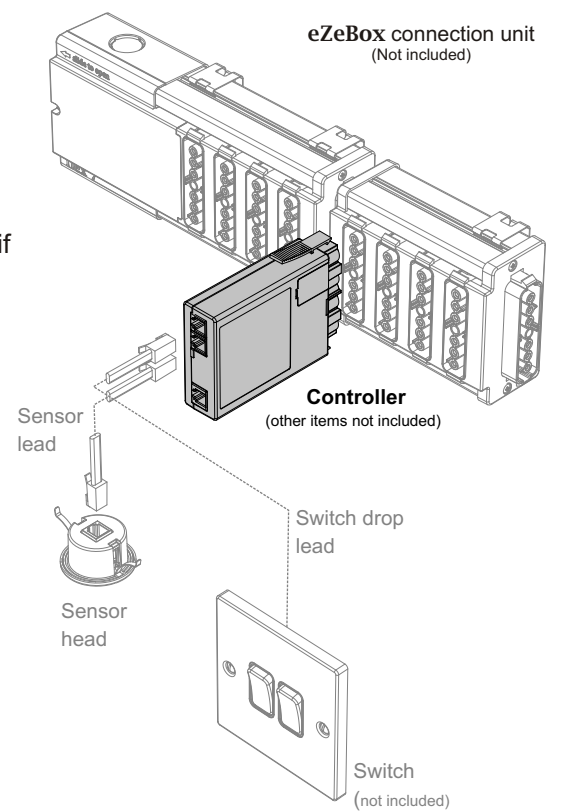

Configuring the **fnc2000/2** controller and wiring the connection unit

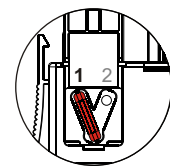
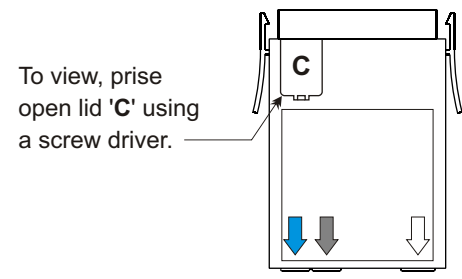

Link MUST be in position 1 as shown
Wire connection unit as shown on the back page.

Rating	
Supply Voltage	: 230V~ 50Hz
Load on Lighting Circuit 1	
Flourescent & Incandescent Lighting	: 6A
Compact Flourescent Lighting	: 3A
Load on Lighting Circuit 2	
Flourescent & Incandescent Lighting	: 6A
Compact Flourescent Lighting	: 3A
Total Maximum Load	:10A

Circuit diagram for **fnc2000/2**

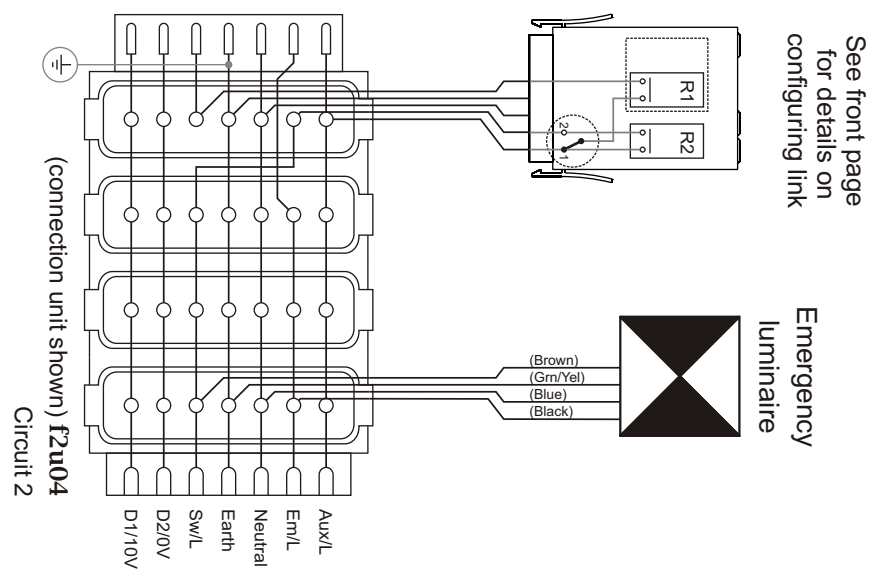
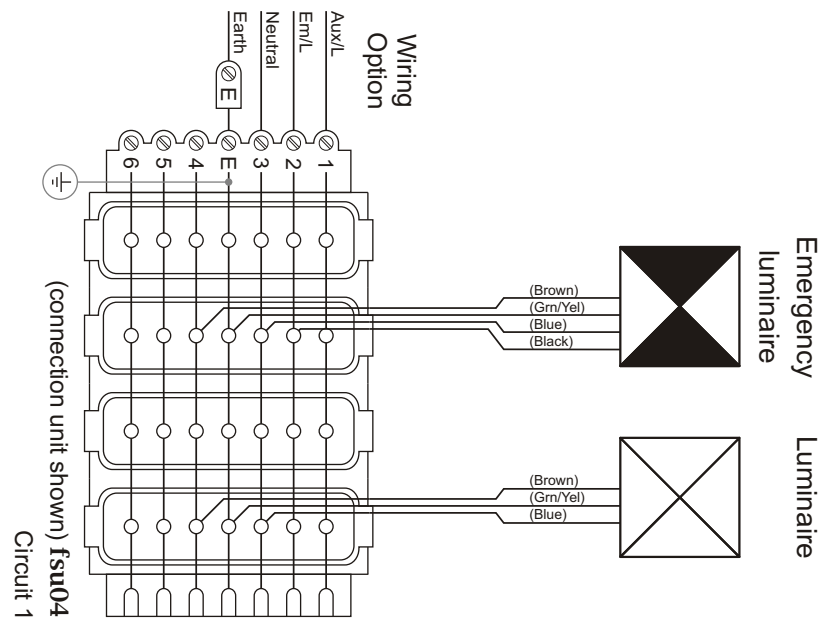

Using an fnc2000/2 controller with a switch only

* Refer to leaflet *Networking Sensors*, leaflet number 17/245.

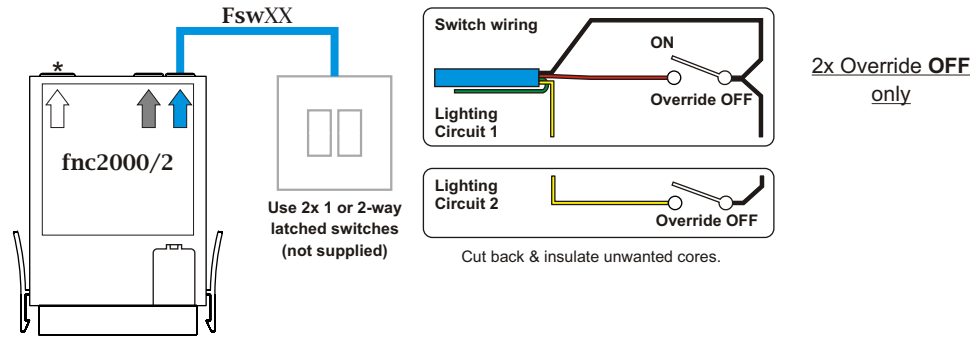

Operation:

switch control:

Lighting circuit 1:

Override OFF - turns the lights OFF.

Lighting circuit 2:

Override OFF - turns the lights OFF.

Note:

If your room requires 2-way switching, a special 'Y' connector is available to enable two switch drop leads to be connected. (Part No. **fsy/2e/2** - OFF control from 2 x 2-way switches)

Using an fnc2000/2 controller with a sensor head and override switch

* Refer to leaflet *Networking Sensors*, leaflet number 17/245.

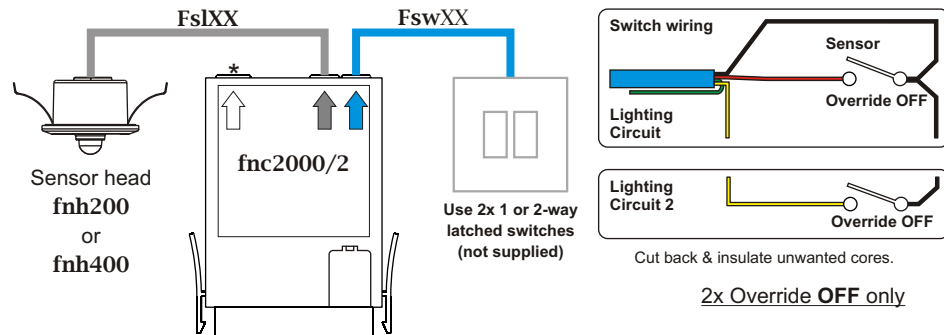

Note:

For safe operation it is advisable that occupancy coverage extends to cover the wall switch. In this way, operating the switch to 'SENSOR' position ensures the lights turn ON.

Note:

If your room requires 2-way switching, a special 'Y' connector is available to enable two switch drop leads to be connected. (Part No. **fsy/2e/2** - OFF control from 2 x 2-way switches)

Other switching options incorporating override ON

Note:

You may not be able to claim enhanced capital allowances under the Carbon Trust scheme if you incorporate local 'override ON' switches in your occupancy sensor scheme.

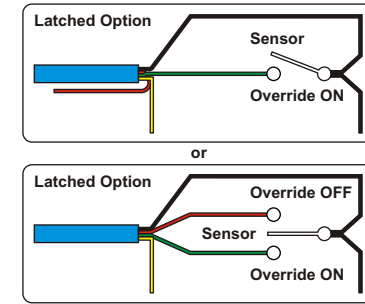

Lighting circuit 2

For lighting circuit 2, wire the yellow and black wire in the switch as shown on the previous diagrams.

Operation:

If the sensor head is of type fnh200

switch control:

Lighting Circuit 1:

Override OFF - turns the lights OFF (takes priority over occupancy)

Lighting circuit 2:

Override OFF - turns the light OFF. (takes priority over occupancy)

Occupancy detection: Provided the corresponding switch drop for that lighting circuit is in the sensor position. The corresponding lights will switch ON whenever there is occupancy detected by the sensor head. When occupancy is no longer detected, all the lights will switch OFF after a pre-selected *time-out* period (default 20 minutes).

If the sensor head is of type fnh400

switch control: As above (fnh200)

Occupancy detection:

Lighting Circuit 1: Provided the wall switch for lighting circuit 1 is in the 'Sensor' position, then, notwithstanding 'daylight dependency' (see below) the lights will switch ON whenever there is occupancy detected by the sensor head. When occupancy is no longer detected, all the lights will switch OFF after a pre-selected *time-out* period (default 20 minutes).

Lighting Circuit 2: Provided the wall switch for lighting circuit 2 is in the sensor position, the lights for lighting circuit 2 will switch on. When occupancy is no longer detected, all the lights will switch OFF after a pre-selected *time-out* period (default 20 minutes).

Daylight dependency (lighting circuit 1 only): If enabled, during periods of occupancy the lights will switch OFF if the ambient light detected under the sensor head exceeds the *set level*.

Note: Alternative operational options not necessarily shown above are available using the **frc/set** setup remote control.

Full instructions for setting up the sensor are supplied with the sensor head and the **frc/set** remote control - both ordered separately.