

The fns3200D(X, A)/U sensor kit plugs directly into any of the eZeBox range of connection units or a 7-pole single socket outlet to provide control of the connected mains rated luminaires. Control is ON/OFF/DIM, dependent on occupancy. The kit comprises a controller, sensor head, and sensor lead.

Three products are available:
fns3200D/U for DSI digital dimmable ballasts.
fns3200X/U for DALI digital dimmable ballasts.
fns3200A/U for Analogue ballasts 0-10V.

Please ensure the correct product is selected for the type of ballast being used as incorrect connection may damage the controller.

This product should only be installed by a qualified electrician.

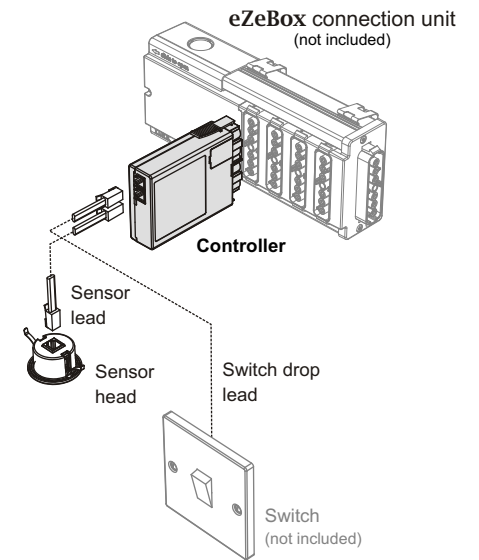

Sensor head and occupancy detection performance

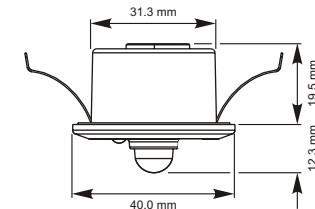
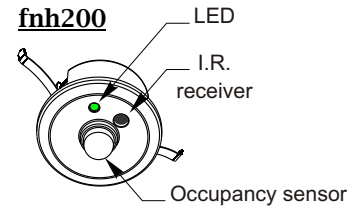

The sensor head fits into a 32mm diameter hole, with clips which can grip ceiling panels down to 1.5mm thick.

The sensor head has a rectangular occupancy detection range broadly 7.4m x 5.6m at a ceiling height of 2.5m (Longest length of detection aligning with the spring clips). As the ceiling height increases so will the overall detection area but sensitivity to small movements will decrease.

Note: Make sure that the sensor is not adjacent to circulating air, heaters or lamps.

Detection Zone

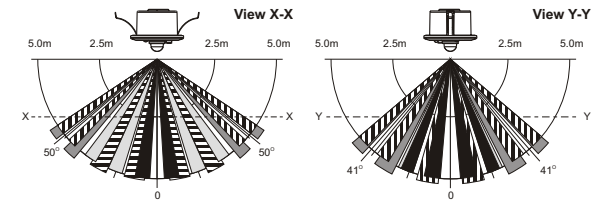
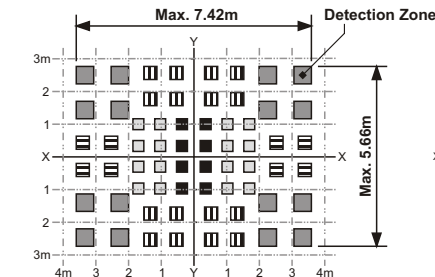

The X-Y cross-sectional diagram shows the detection area. The differences in the detection zone patterns indicate the projections of the 16 lenses with a single focal point. Movement of an object with higher than background temperature, between the detection zones, will be detected.

Configuring the controller and wiring the connection unit

Prise open lid 'C' using a screw driver. Position link as required.

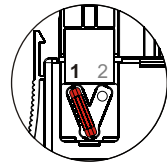
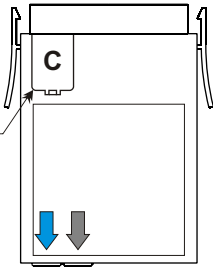

Link in position 1

Lights can remain ON during an emergency test. Wire connection unit as shown on page 5.

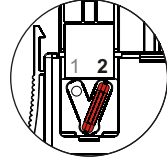

Link in position 2

Lights will switch OFF during an emergency test. Wire connection unit as shown on page 5.

Rating

Supply Voltage : 230V~ 50Hz

Load

Flourescent & Incandescent Lighting : 6A

Compact Flourescent Lighting : 3A

Maximum number of Ballast

fnc3000D/U (DSI Digital control) : 25

fnc3000D/U (DALI Digital control) : 25

fnc3000D/U (Analogue 0-10V control) : 25

Switching Option 1

Absence + Manual dimming using a 3- position retractive Switch

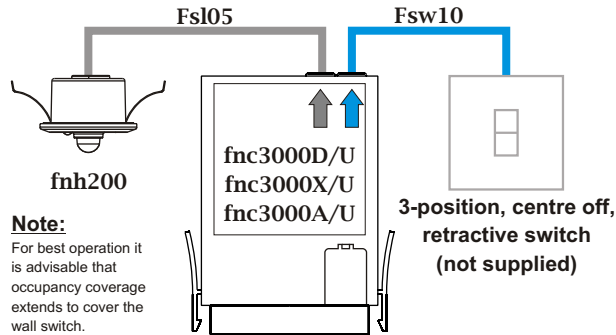

Note: Multiple switches can be connected in parallel. 'Y' connectors are available to enable two switch drop leads to be connected into one point. (Part No. fsy/A - adaptor)

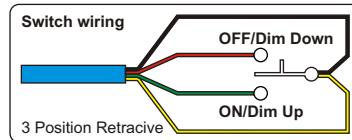

Operation:

Switch control:

ON pulse - turns the lights ON.

OFF pulse - turns the lights OFF.

A long ON pulse - brightens lights (eventually to maximum).

A long OFF pulse - dims lights (eventually to minimum, but should the pulse exceed 15 secs the lights will switch OFF completely).

Absence detection: When occupancy is no longer detected, lights will switch OFF after a pre-selected *time-out* period (default 20 minutes).

Note: Alternative operational options not necessarily shown above are available using the **frc/set** setup remote control.

Full instructions for setting up the sensor are supplied with the sensor head and the **frc/set** remote control - both ordered separately.

Setting up your sensor

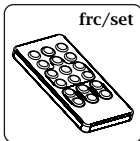

frc/set

Setup Remote Control - frc/set

Your sensor comes factory set with a 20 minute occupancy time out, however you will require an frc/set remote control (ordered separately) to set up daylight linking. You may also require one if another time out period is required (2,5,10,20 and 40 minutes) or other operational options are desired. Full instruction for setting up the sensor are supplied with the frc/set remote control.

Optional Extras/Spares

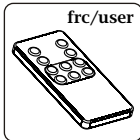

frc/user

User Remote Control - frc/user

The frc/user remote control is a convenient method for the user to control the lighting remotely. Lights can be temporarily overridden ON or OFF dimmed UP or DOWN. In addition, up to six preset light levels can be stored and recalled.

Note: Unlike the frc/set remote control the frc/user remote control can not be used to setup or change occupancy time-out settings.

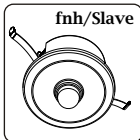

fnh/slave

Increasing Occupancy Coverage - fnh/slave

Occupancy coverage can be increased by adding up to a maximum of five slave sensor heads (fnh/slave) to your existing sensor head. The fnh/slave comes complete with a 'Y' adaptor to facilitate connection.

A connecting lead may also be required, part number fslXX (XX = length /5m).

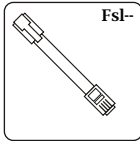

fsl-

Increasing Occupancy Coverage - fnh/slave

Occupancy coverage can be increased by adding up to a maximum of five slave sensor heads (fnh/slave) to your existing sensor head. The fnh/slave comes complete with a 'Y' adaptor to facilitate connection.

A connecting lead may also be required, part number fslXX (XX = length /5m).

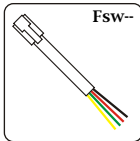

fsw--

PELV - Switch Drop

To add additional switches a PELV switch drop lead and a fsy/a will be required to connect the additional switch to the control unit.

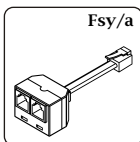

fsy/a

Fsy/a

If your room requires additional sensor heads (fnh/slave) or additional switch drops you will require an fsy/a to link your additional cables into.

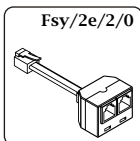

fsy/2e/2/0

Fsy/2e/2/0

If your room requires 2-way switching you will require in addition:

1 x fsy/2e/2/0 - 'Y' adaptor for 2 x 2-way.

1 x fswXX - Switch drop lead.

(XX = length in metres in multiples of 5m).

Switching Option 2

Absence + Manual dimming using a 1-way Retractive Switch

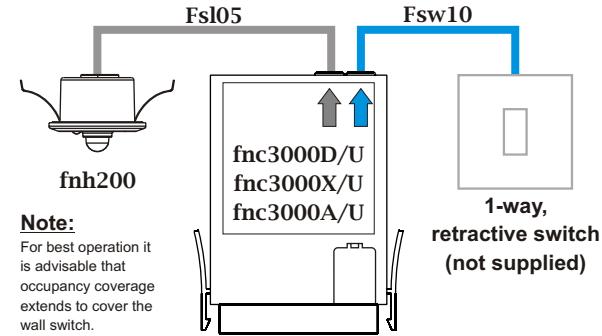

Note:

For best operation it is advisable that occupancy coverage extends to cover the wall switch.

Note: Multiple switches can be connected in parallel. 'Y' connectors are available to enable two switch drop leads to be connected into one point. (Part No. fsy/A - adaptor)

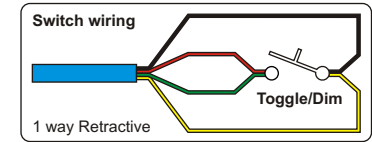

Operation:

Switch control:

Pulse - turns the lights ON or OFF (when turning ON, lights adopt last dimmed level).

A long pulse - dims or brightens the lights (but should the pulse exceed 15 secs the lights will switch OFF completely).

Absence detection:

When occupancy is no longer detected, lights will switch OFF after a pre-selected *time-out* period (default 20 minutes).

Note: Alternative operational options not necessarily shown above are available using the frc/set setup remote control.

Full instructions for setting up the sensor are supplied with the sensor head and the frc/set remote control - both ordered separately.

Switching Option 3

Occupancy with override - using latched switching

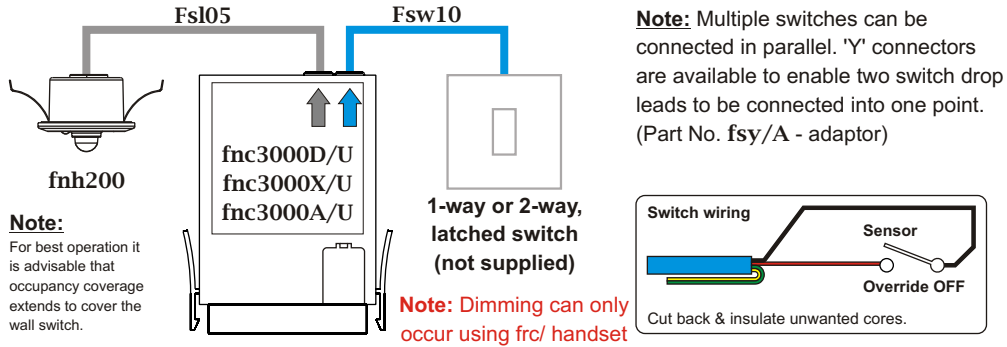

Operation:

Switch control: Override OFF - turns the lights OFF (takes priority over sensing).

Occupancy detection: Provided the wall switch is in the 'Sensor' position the lights will switch ON whenever there is occupancy detected by the sensor head. When occupancy is no longer detected, lights will switch OFF after a pre-selected *time-out* period (default 20 minutes).

Note: Alternative operational options not necessarily shown above are available using the frc/set setup remote control.

Full instructions for setting up the sensor are supplied with the sensor head and the frc/set remote control - both ordered separately.

Other switching options incorporating override ON

Note:

You may not be able to claim enhanced capital allowances under the Carbon Trust scheme if you incorporate local 'override ON' switches in your occupancy sensor scheme.

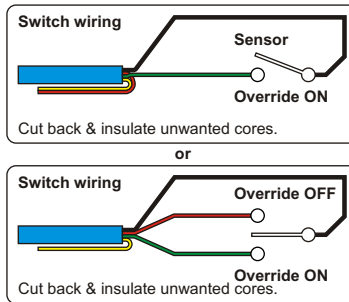

Circuit diagram for fnc3000(D,X or A)/U Controller

