

TO SETUP AND STORE SCENES

1. Enter scene setting mode: Press and hold the MODE button (approx. 5 secs.) LED's 1 to 4 will illuminate and the MODE LED will flash slowly.
2. Enter the pin: Use the appropriate buttons 1 to 4 to enter either the factory default pin number 4321 or if previously altered, the new pin. LEDs 1 to 4 flash twice after the correct pin is entered (or 5 times if incorrect - in which case 5 further attempts are allowed).
3. Set up a scene: Starting with channel 1, adjust the luminaires to the desired brightness by using short presses on button 1 to toggle lights ON / OFF or long presses to dim them UP / DOWN. Repeat for channels 2, 3 & 4 using buttons 2, 3 & 4 respectively.
4. Store the scene: Once satisfied with the scene you have set up, press the MODE button (MODE LED will now flash rapidly) followed by whichever of buttons 1 to 4 that you wish to store the scene to - Its associated LED will flash twice to denote your scene has been successfully saved and the mode LED will return to flashing slowly.
5. Set up more scenes OR exit scene setting: To set up more scenes repeat steps 3 and 4 (Max. 4 storable scenes) OR to exit scene setting by pressing and holding the MODE button for 5 seconds. LED's 1 - 4 will flash 3 times – then the unit now returns to the scene mode. (Note: This occurs in any case if the unit is inactive for longer than 2 minutes)

TO CHANGE THE PIN

1. Enter change pin mode: Press and hold the ON/OFF button (approx. 5 secs.) LED's 1 to 4 will illuminate and the MODE LED will flash slowly.
2. Enter the current pin: Use the appropriate buttons 1 to 4 to enter either the factory default pin number 4321 or if previously altered, the new pin. LEDs 1 to 4 flash twice after the correct pin is entered (or 5 times if incorrect - in which case 5 further attempts are allowed).
3. Enter the new pin: Enter the new pin. LED's 1 to 4 will flash once.
4. Re-enter the new pin: Enter the new pin again. LED's 1 to 4 will flash twice if they both match. If they don't match LED's 1 - 4 will flash 5 times, repeat step 3.

The new pin will now be saved and the unit will return to scene mode.

TECHNICAL

- | | | | |
|--------------|--------|---------------|-----|
| • Rating | 12v DC | • Compliance: | TBC |
| • IP Rating: | IP20 | | |



Flex Connectors Limited, Ruscombe Business Park, Ruscombe Lane, Twyford, Berkshire RG10 9LR, UK
 Telephone: +44 (0) 20 8580 1066 Fax: +44 (0) 20 8580 1062
 Website: www.flexconnectors.co.uk Email: info@flexconnectors.co.uk
 Leaflet reference number: 22/094 Issue 2 08/03/2017



FSS04 INSTRUCTIONS

Thank you for purchasing the Flex7 Scene Setting Panel (FSS).

Working in conjunction with a Flex Connectors' ZoneLite (not supplied), the FSS controls up to 4 channels of lighting and is unique in providing the end user with not one, but two normal modes of control. A single button seamlessly toggles from one mode to the other:

Scene Mode - Allows the user to select any 1 of 4 pre-stored scene.

Channel Mode - Allows the user to operate and adjust each channel independently.

In addition and provided a suitable ZoneLite sensor head has been fitted, all lights can be controlled by occupancy i.e. on vacation of the space any luminaires left on will switch off after an adjustable time-out period.

Four models are available:

- FSS04/M/W - White module
- FSS04/M/B - Black module
- FSS04/K/W/WP - White module with white face plate
- FSS04/K/B/SS - Black module with brushed stainless steel face plate

Please read the instructions carefully before installing the FSS and leave them with the user for future reference.

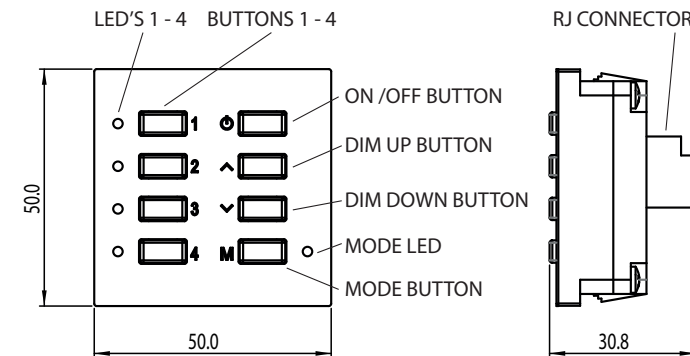

FIGURE 01

LOCATION AND FIXTURE

The FSS must be securely fixed to a suitable surface (wall) via a single gang 30mm (or deeper) UK back box.

Models supplied without a face plate are designed to clip into a UK Single Gang, 2 Euro Module Plate which can in turn be fixed to a suitable surface (wall) via a single gang 30mm (or deeper) UK back box - refer to fig. 2

Ensure there are no hidden services (gas, electricity or water) before fixing the back box.

Location of the FSS should be such that it is in an ideal position for the user relative to the luminaires it is controlling, meets relevant building & electrical regulations, and allows for routing of the connecting cable to the Flex ZoneLite.

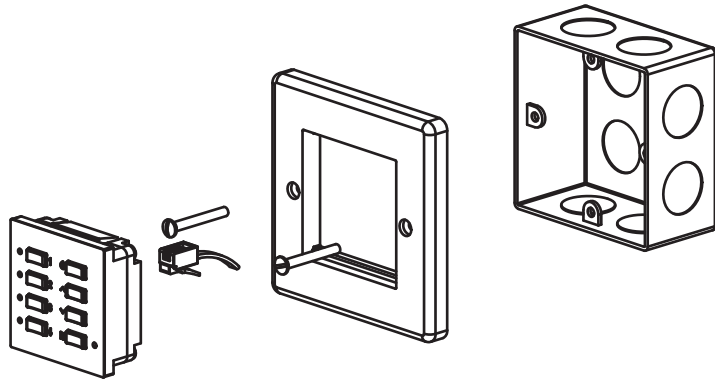

FIGURE 02

ELECTRICAL

ENSURE ELECTRICAL POWER IS SWITCHED OFF BEFORE MAKING ANY CONNECTIONS TO THE FLEX7 SCENE SETTING PANEL.

- The FSS must be connected to Port A of the Flex Connectors' ZoneLite via a Flex FSL type sensor lead (not supplied). Please note that connecting the FSS to any other port will result in incorrect operation - *refer to fig. 3*
- A maximum of 3 FSS's may be connected in series to a Flex7 ZoneLite using FSY Leads (not supplied). - *refer to fig. 3*

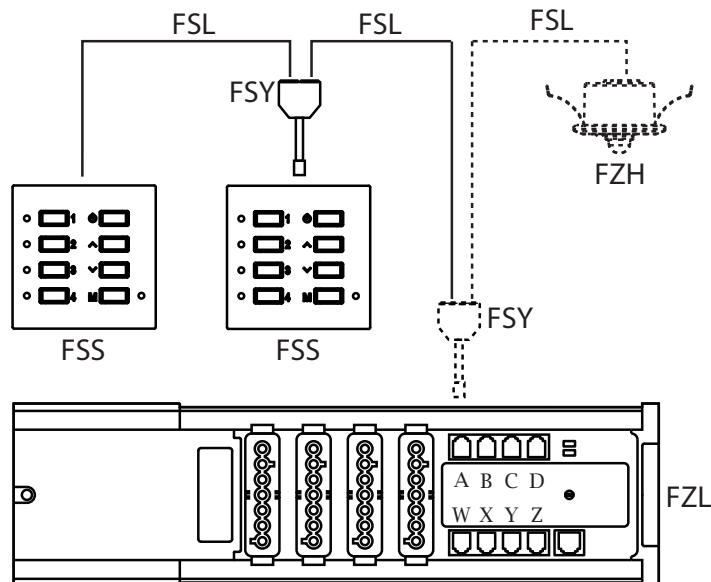

FIGURE 03

COMMISSIONING

- Ensure the Flex7 ZoneLite has been installed correctly.
- Switch the FZL to Configuration 9 (Type T) or Configuration A (Type G).
- Switch the electrical supply to the FZL
- All LED's on the FSS will be OFF and all dimmable luminaires will be at 50% brightness whilst non-dimmable will be on.
- Press the MASTER ON/OFF button to turn ALL luminaires ON.

MODE SELECTION - refer to fig. 1

- The FSS operates in 2 modes: CHANNEL and SCENE.
- Press the MODE Button to toggle between the two.
- The MODE LED is OFF when in SCENE mode.
- The MODE LED is ON when in CHANNEL mode.

SCENE MODE - refer to fig. 1

- Allows the user to select any 1 of 4 scenes or temporarily adjust the active scene up, down or off
- Buttons 1 to 4 recall pre-stored scenes. The respective LED illuminates to indicate the selected scene
- Press and hold the MASTER DIM UP or MASTER DIM DOWN buttons to temporarily adjust the overall brightness of the selected scene
- Press (briefly) the MASTER ON/OFF button to turn ALL luminaires OFF or ON (ON = on to last known state)

CHANNEL MODE - refer to fig. 1

- Allows the user to adjust each channel independently
- Buttons 1 to 4 operate each channel respectively. Use short presses to toggle lights ON / OFF or, while ON, press and hold to dim them either UP or DOWN (alternates)
- Press and hold either the MASTER DIM UP or MASTER DIM DOWN button to temporarily adjust the overall brightness of the scene
- Press (briefly) the MASTER ON/OFF button to turn ALL luminaires OFF or ON (ON = on to last known state) Note: If channel was originally OFF it will switch ON at minimum brightness.